

Simulation Snapshots

A. Melatos (UMelb)

Web Resources for Theorists

- Public source code
 - omnipotent** 😊 controllable 😊
 - BUT** steep learning + computing curve
- Raw simulation output
- Web form interface to private source code
- Pictures and movies
 - quick & easy**
 - BUT** not quantitative or transparent

Examples

- 3D magnetohydrodynamics code – Zeus
[zeus.htm](#) [zeus3D.htm](#)
- Raw LSS simulation output – Virgo
[virgo.htm](#)
- Chemical evolution “calculator” – Swinburne
[chemical.htm](#)
- Pictures and movies – many examples!

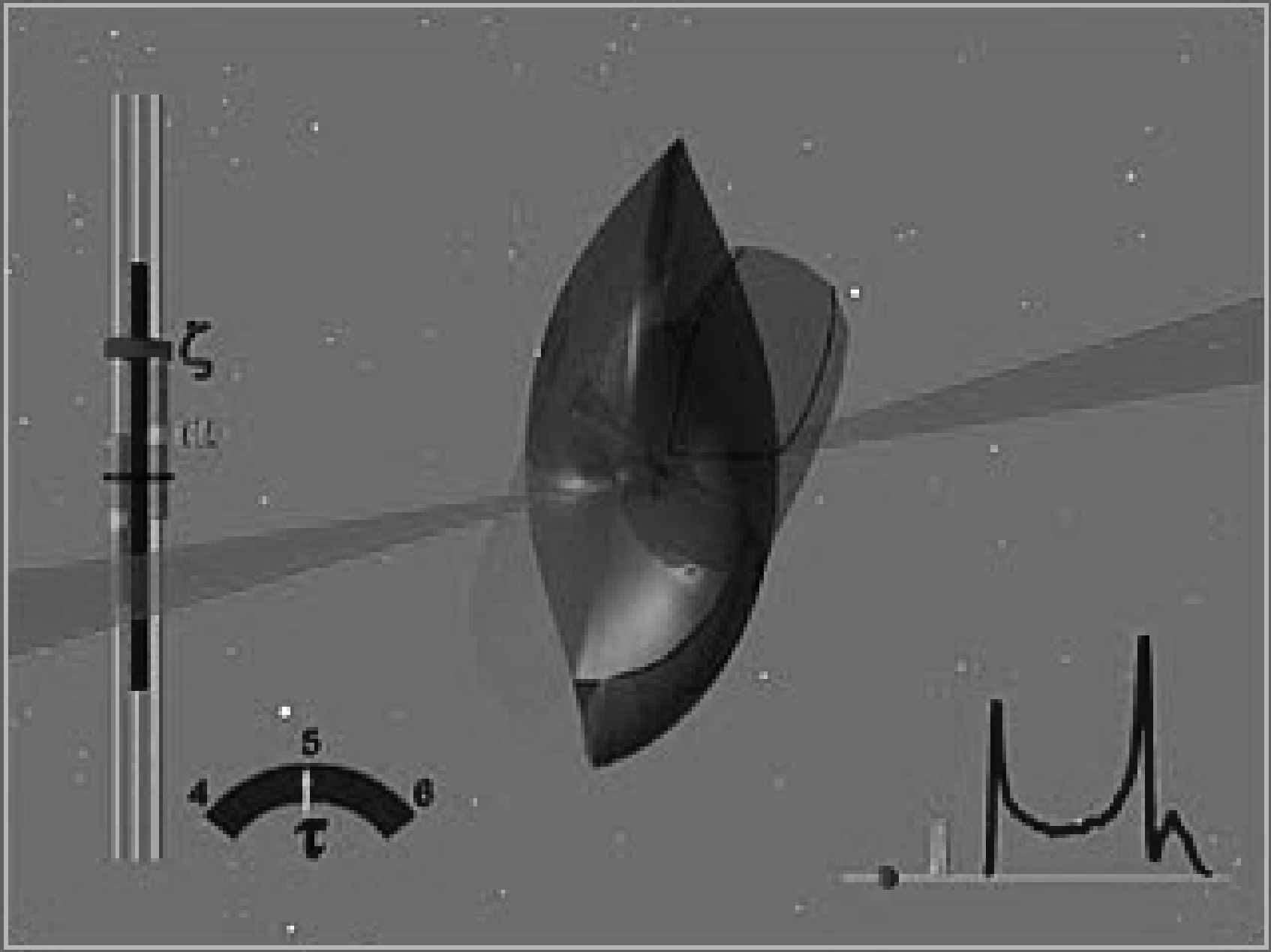

Library of Snapshots

Numerical solutions of **precisely defined** problems of **general interest** in key fields, stored in a **standard, low-level format** convenient for detailed post-processing. *

* **Packaged with analysis + visualization tools**

Why Snapshots?

- **Testing:** parent VO code, other codes (VO or local), analytic theory
- Simple “toy” problems, but also “serious” problems with realistic parameters
- **Post-processing** ® **science:** statistics, “synthetic telescope”, initial condition...
- Example: **accretion disks**

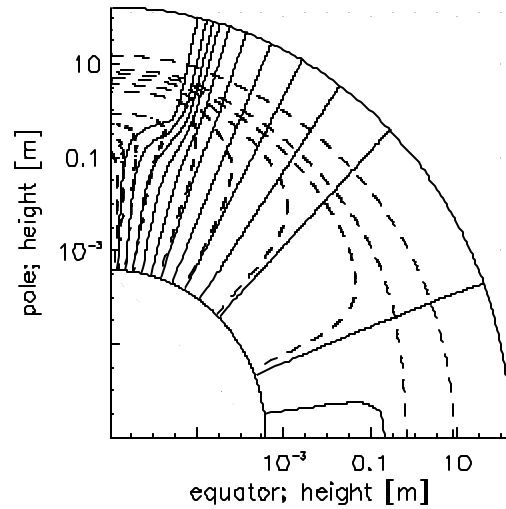

Figure 4. Polar plot of equilibrium magnetic field lines for $M_{\text{in}} = 10^{-5} M_{\odot}$ (solid), coordinate in the height above the stellar surface. Density values (max/min) at the pole (η , ρ_{max} ; ρ_{min}) $2.52 \times 10^{17} \text{ kg m}^{-3}$ ($\eta = 0.8, 0.6, 0.4, 0.2, 0.0, 0.00, 10^{-1}, 10^{-2}, 10^{-6}, 10^{-12}$) (dashed).

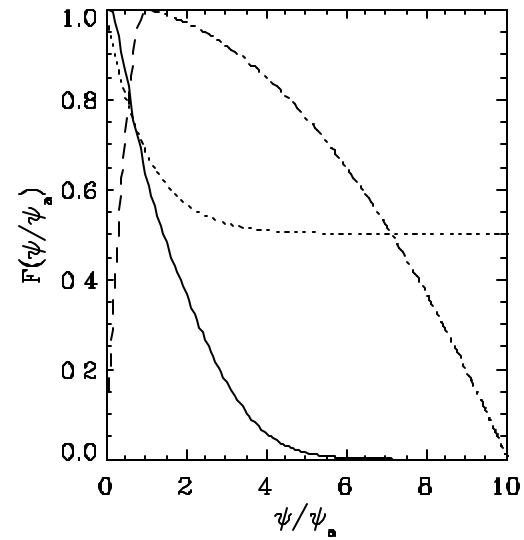
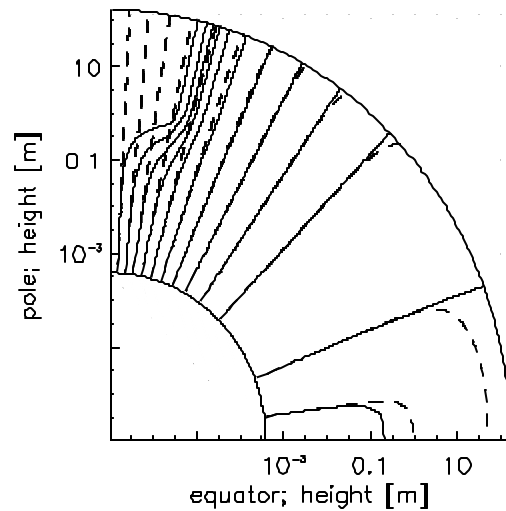

Figure 6. Comparison of our $P(\psi)$ (solid) with others in the literature, MPO (dashed), B398 (dotted) and L10 (dot-dashed). These have all been scaled to their value at the pole. We need to show the PROPER SCALING.

Magnetohydrodynamic equilibria & stability

Implementation Issues

- **Precise definition.** Equations + physics, boundary + initial conditions, parameters, algorithms... everything you need to reproduce the snapshots independently!
- **Format. Standardized!**
- **Topic areas.** Classic problems of general interest... “toy” (e.g. shock), “astro” for science (e.g. LSS, disks, jets, atmospheres)